

SMALL BLOCK CHEVY ALTERNATOR BRACKET

HEAD MOUNT, FOR SHORT WATERPUMP



Put the polished 3/4 in. spacer in the counter-sunk hole before you put a bolt in. the bolt path should be...first thru the adjuster rod end, into the 3/4 in. spacer which is in the bracket, then into the block. This will allow proper spacing for adjustment

“ THE CONVERTIBLE BRACKET ”

714) 298-9060

PART NUMBER

7740

Parts list.

- (1) Main Bracket A
- (1) Main Bracket B
- (1) 10 O'Clock Bracket
- (1) 6.0 adjuster rod
- (1) Set Rod Ends (R&L)
- (1) Polished 3/4 in. spacer
- (1) Bolt Kit

***** THE 7740 BRACKET IS NICKNAMED THE CONVERTIBLE FOR A REASON. ALTHOUGH THE 7740 AS SHIPPED IS FOR THE SHORT STYLE WATER PUMP. WE DESIGNED IT FOR BOTH SHORT AND LONG WATER PUMPS. IF YOU DECIDE TO RUN A LONG PUMP, DON'T WORRY, WE HAVE YOU COVERED. YOU WILL JUST NEED TO CALL US AND PURCHASE A LONG PUMP UPGRADE.**

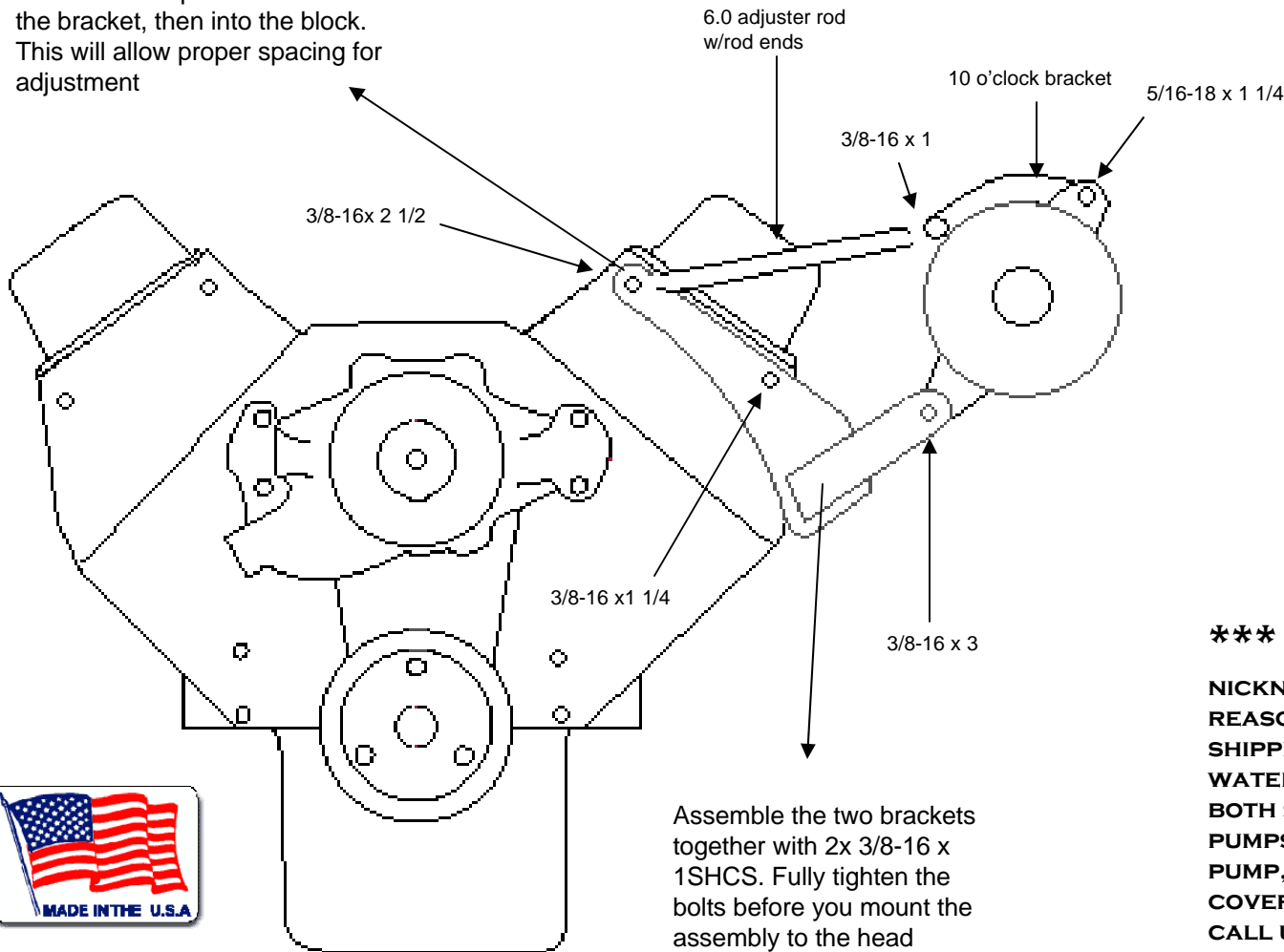

Assemble the two brackets together with 2x 3/8-16 x 1 SHCS. Fully tighten the bolts before you mount the assembly to the head

